



# MEZS7-2SBoostCharger

## 2-Cell Li-Ion/Li-Polymer Switching Charger for 5V Input & Integrated Cell balance Solution Module

### DESCRIPTION

The MEZS7-2SBoostCharger is a complete solution module for charging and balancing two Li-ion or Li-polymer series cells. The solution includes the MP2639C battery charger with integrated FETs, protection features, cell balancing, and LED indicators for battery state of charge.

When input power is present, the MEZS7-2SBoostCharger charges a 2-cell series battery with a 2.5A charge current and ensures the two cells stay balanced.

The MEZS7-2SBoostCharger provides 4 LED drivers to achieve the voltage-based fuel gauge indication.

To guarantee safe operation, the MEZS7-2SBoostCharger has input over-voltage protection, battery over-voltage protection, thermal shutdown, JEITA battery temperature monitoring, and a charge timer to prevent prolonged charging of a dead battery. The solution can also be configured to provide a regulated 5V output back to the USB port in discharge mode, in accordance with USB on-the-Go and USB Type-C specifications.

### ELECTRICAL SPECIFICATIONS

Parameter	Symbol	Value	Units
<b>Charge Mode</b>			
Input voltage range	$V_{IN}$	4 to 5.75	V
Charge-full voltage	$V_{BATT\_FULL}$	8.4	V
Auto-recharge Voltage	$V_{RECH}$	8	V
Charge current	$I_{CHG}$	2.5	A
Input current limit	$I_{IN\_LIM}$	3	A

### FEATURES

- 4V to 5.75V Input Voltage Range
- Charges a 2-Cell Battery with a 5V Input
- USB-Compliant Charger
- Integrated Input Current Based and Input Voltage Based Power Management Function
- Input Current at 3A and Input Voltage Limit at 4.49V
- 2.5A Charge Current for 2-Cell Applications
- 8.4V Charge Voltage with 0.5% Accuracy
- Negative Temperature Coefficient Pin for JEITA Temperature Monitoring
- Charge Timer Backup Protection
- Thermal Regulation and Thermal Shutdown
- 4-LED Battery Level and Status Indication
- Available in a QFN-26 (4mmx4mm) Package

### APPLICATIONS

- Wireless Speakers
- Gimbals
- E-Cigarettes
- Battery Backup Systems

All MPS parts are lead-free, halogen-free, and adhere to the RoHS directive. For MPS green status, please visit the MPS website under Quality Assurance. "MPS", the MPS logo, and "Simple, Easy Solutions" are trademarks of Monolithic Power Systems, Inc. or its subsidiaries.

MEZS7-2SBOOST CHARGER SOLUTION MODULE



(LxWxH) 3cmx2.8cmx0.16cm

Board Number	MPS IC Number
MEZS7-2SBoostCharger	MP2639CGR

## QUICK START GUIDE

This solution module is for the MP2639C, a flexible switch-mode battery charging management device for a 2-cell series Li-ion and Li-polymer battery pack used in a wide range of portable applications through the boost converter from VL to VH.

The solution module's layout accommodates most commonly used capacitors. The default function of this solution module is preset to charge mode, and the charge-full voltage is preset to 8.4V for a 2-cell series Li-ion battery.

### Charge Mode Setting

#### 1. Input Current Limit

An input current limit can be set slightly below the input source's maximum current rating. When the input current reaches this limit, the charge current decreases to keep the input current constant at the limit value to initially power the system. The resistor connected to the ILIM pin ( $R_{ILIM}$ ) programs this limit. To set the input current limit at 3A, use an  $R_{ILIM}$  of 71.5k $\Omega$ . Calculate  $I_{INLIMIT}$  using Equation (1):

$$I_{INLIMIT} = \frac{640k\Omega}{3 \times R_{ILIM}} \quad (1)$$

#### 2. Charge Current

The charge current can be programmed via  $R_{ISET}$ . Determine the charge current using Equation (2):

$$I_{CHG} = \frac{640k\Omega}{3 \times R_{ISET}} \quad (2)$$

For a 2.5A charge current, the given  $R_{ISET}$  is 85.3k $\Omega$ .

#### 3. Input Voltage Limit

The input voltage clamp threshold is programmable by the VLIM pin. The internal reference of the input voltage loop is 1.2V. Determine the input voltage clamp limit using Equation (3):

$$V_{INLIMIT} = 1.2 \times \frac{R_3 + R_4}{R_4} \quad (3)$$

Where  $R_3 = 27.4k\Omega$ ,  $R_4 = 10k\Omega$ , the input voltage clamp value is 4.49V.

## EQUIPMENT REQUIREMENTS

Evaluation requires the following equipment:

1. A USB cable with an adapter or any USB port with load capability (for the charge input) can be used for the solution module. If a certain operation state cannot be tested, an external wire can be added to connect a power source with 6V/3A capability.
2. A battery simulator or 2-cell battery pack. The battery simulator's output rating should be greater than 9V/7.0A. When using a real battery pack, review all precautions in the battery manufacturer's datasheet and ensure the charger's setting does not exceed the battery's absolute maximum specifications.
3. An oscilloscope with a single voltage probe and a single current probe.
4. A multi-meter.

### Charge Function

1. Attach the positive (VH) and negative ends (PGND) of the board to the "+" and "-" terminals of the battery or battery simulator, respectively. If using a battery simulator, preset the voltage to 7.6V (typical value for 2-cell) first.
2. Attach the USB cable to the USB1 port.

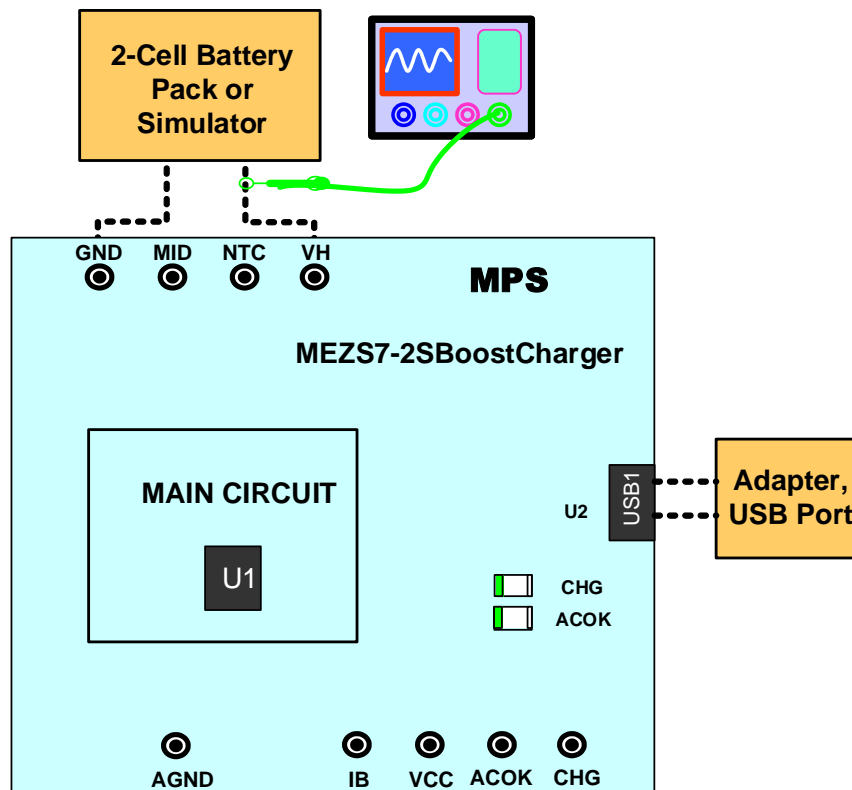

Figure 1: Set-Up for Charge Mode from USB Cable

3. Insert the USB cable; charging should start. Use the oscilloscope to verify that the charge current is being delivered to the battery. The charge current could be a different value under the following conditions:

- a. The charge current is limited by the input current limit.

The IC features input source detection to determine the input current limit according to the input source (USB or adapter). The IC sets the input current limit through the ILIM pin. When the input current reaches this limit and the battery voltage continues to increase, the charge current decreases to keep the input current constant at the limit value.

- b. The charge current is limited by the input voltage regulation.

If the input power supply has lower current capability than the input current limit (such as a USB with only 500mA capability) or the voltage loss on the USB cable is too big, the input voltage may approach the input voltage regulation threshold (4.49V) preset by R3 and R4. Once the input voltage approaches the input voltage regulation threshold, the charge current is reduced to allow priority of the system power and keep the input voltage from dropping further.

For additional information on MP2639C operation, refer to the MP2639C datasheet.

SOLUTION MODULE SCHEMATIC

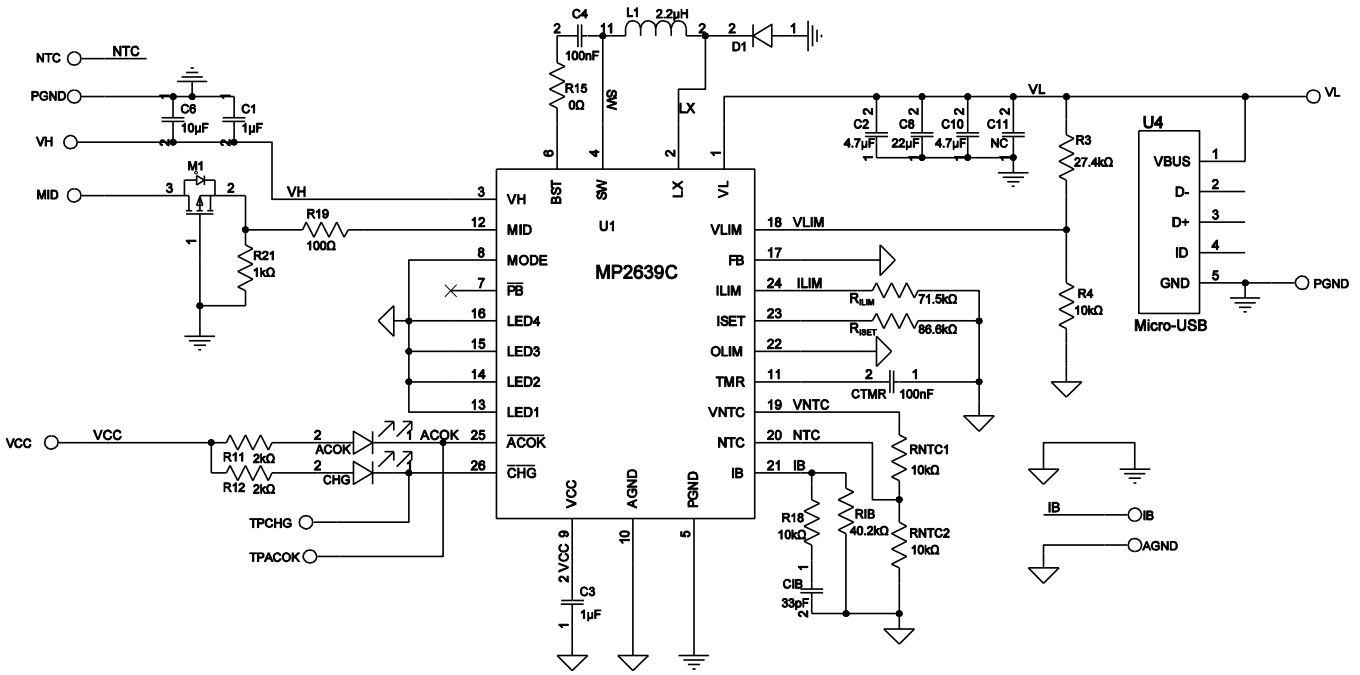

$R_{ILIM} = 432k\Omega$  for 500mA ILIM,  $R_{ILIM} = 76.6k\Omega = 432k\Omega/93.1k$  for 2.79A ILIM,  $R_{ILIM} = 640k\Omega/3/ILIM$   
 $R_{IBET} = 86.6k\Omega$  for 2.46A ICHG,  $R_{IBET} = 640k\Omega/3/CHG$

Figure 2: Solution Module Schematic

**MEZS7-2SBOOST CHARGER BILL OF MATERIALS**

Qty	Ref	Value	Description	Package	Manufacturer	Manufacturer PN
1	R3	27.4kΩ	Film resistor, 1%	0603	Yageo	RC0603FR-0727K4L
3	R4, R18, RNTC1	10kΩ	Film resistor, 1%	0603	Yageo	RC0603FR-0710KL
1	RNTC2	15kΩ	Film resistor, 1%	0603	Yageo	RC0603FR-0715KL
2	R11, R12	2kΩ	Film resistor, 1%	0603	Yageo	RC0603FR-072KL
1	R15	0Ω	Film resistor, 5%	0603	Yageo	RC0603FR-070RL
1	R19	100Ω	Film resistor, 1%	0603	Yageo	RC0603FR-07100RL
1	R21	1kΩ	Film resistor, 1%	0603	Yageo	RC0603FR-071KL
1	RIB	40.2kΩ	Film resistor, 1%	0603	Yageo	RC0603FR-0740K2L
1	RILIM	79kΩ	Film resistor, 1%	0603	Yageo	RC0603FR-0779KL
1	RISSET	86.6kΩ	Film resistor, 1%	0603	Yageo	RC0603FR-0786K6L
2	C1, C3	1μF	Ceramic capacitor, 25V, X7R	0603	Murata	GRM188R71E105KA12D
2	C2, C10	4.7μF	Ceramic capacitor, 25V, X5R	0805	Murata	GRM21BR61E475KA12L
2	C4, CTMR	100nF	Ceramic capacitor, 25V, X7R	0603	Murata	GRM188R71E104KA01D
1	C6	10μF	Capacitor, 25V, X7R	1206	Murata	GRM31CR71E106KA12
1	C8	22μF	Capacitor, 16V, X7S	1206	Murata	GRM31CC71C226ME11L
1	C11	NC	NC	NC	NC	NC
1	CIB	33pF	Ceramic capacitor, 50V	0603	TDK	C1608C0G1H330J
1	CHG	BL-HUF35A-TRB	Green LED	0805	Bright LED	BL-HUF35A-TRB
1	ACOK	BL-HGB35A-TRB	Red LED	0805	Bright LED	BL-HGB35A-TRB
1	D1	B330B	Schottky diode, 30V, 3A	SMB	Diodes	B330B-13-F
1	L1	1.2μH	Inductor, 1.2μH, 21mΩ, 4.6A	SMD	Würth	7447745012
1	M1	AM2305PE-T1	P-channel MOSFET, -20V	SOT-23	Analog Power	AM2305PE-T1
1	U1	MP2639C	2-cell Li-ion or Li-polymer switching charger	QFN-26 (4mmx4mm)	MPS	MP2639CGR
1	U4	Micro-USB	Micro-USB 2.0 Type-B	Horizontal	Würth	629105150521

PCB LAYOUT

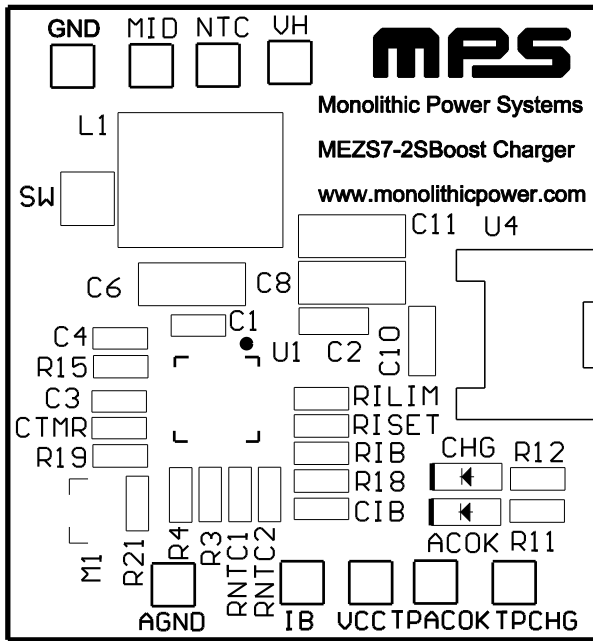

Figure 3: Top Silk Layer

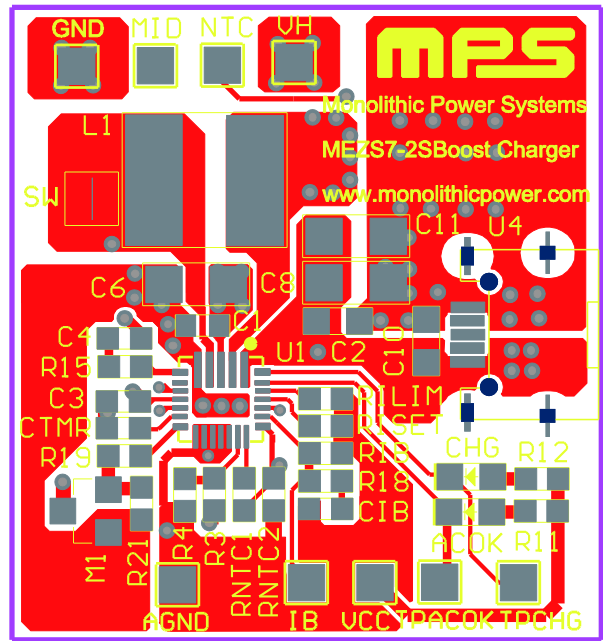

Figure 4: Top Layer

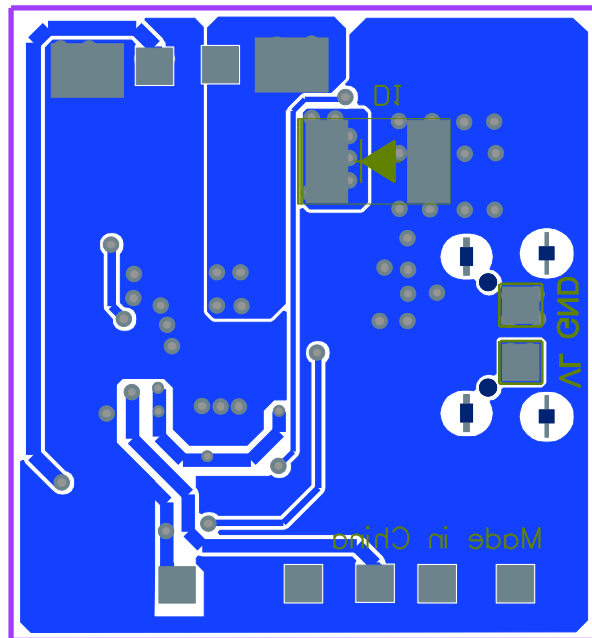

Figure 5: Bottom Layer



## Revision History

Revision #	Revision Date	Description	Pages Updated
1.0	6/18/2020	Initial Release	-
1.1	8/20/2020	Replace MP2639A with MP2639C	P1-P9

**Notice:** The information in this document is subject to change without notice. Please contact MPS for current specifications. Users should warrant and guarantee that third-party Intellectual Property rights are not infringed upon when integrating MPS products into any application. MPS will not assume any legal responsibility for any said applications.

# Mouser Electronics

Authorized Distributor

Click to View Pricing, Inventory, Delivery & Lifecycle Information:

[Monolithic Power Systems \(MPS\):](#)

[MEZS7-2SBoost Charger](#)